



Engineering & Public Services
371 Saco Street
Westbrook, ME 04092
Phone: 207-854-0660

ENGINEERING & PUBLIC SERVICES

Permit # _____

STREET OPENING PERMIT

Date of Application: _____

Name of property owner where work is being performed: _____

Address of work to be performed: _____

Address: _____

Telephone #: _____ Email: _____

Proposed Start Date: _____

Proposed Completion Date: _____

Purpose of Excavation: _____

Name of applicant performing work: _____

Address: _____

Telephone #: _____ Email: _____

24-hour emergency telephone #: _____

Name of applicant's liability & property damage insurance: _____

Address: _____

Policy #: _____

Dig safe authorization #: _____ Date: _____

(Telephone # 1-888-344-7233)

The applicant shall show an 8 1/2" x 11" sketch marked "Exhibit A". Trench locations, trench widths, trench depths, existing utilities, proposed location of barricades, warning signs, detour signs and detour route, where applicable.

NOTE: If any street is to be blocked off, Council approval is required. Once approval is granted, the applicant must notify the Police Department, Fire Department and Public Services. If gas lines are damaged, the applicant must call 911.

In accordance with Chapter 281, Article IV Code of Ordinances for the City of Westbrook.

Pavement Restoration Specification:

Description

Pavement – Paved trenches should be milled out at least 1 foot on either side of the trench and repaved with a minimum of 12.5 mm nominal aggregate sized hot mix asphalt. The ambient temperature should be 40°F and rising to ensure maximum compaction. Pavement should not be placed on top of pavement if it is wet, and gravel will not be paved on top of if puddling is occurring. The trench should have a minimum of 3 inches of pavement with each lift being no more than 1.5 inches in depth.

Aggregate – Aggregate should be put in a maximum of 8-inch lifts and compacted with a plate compactor or 5-ton roller.

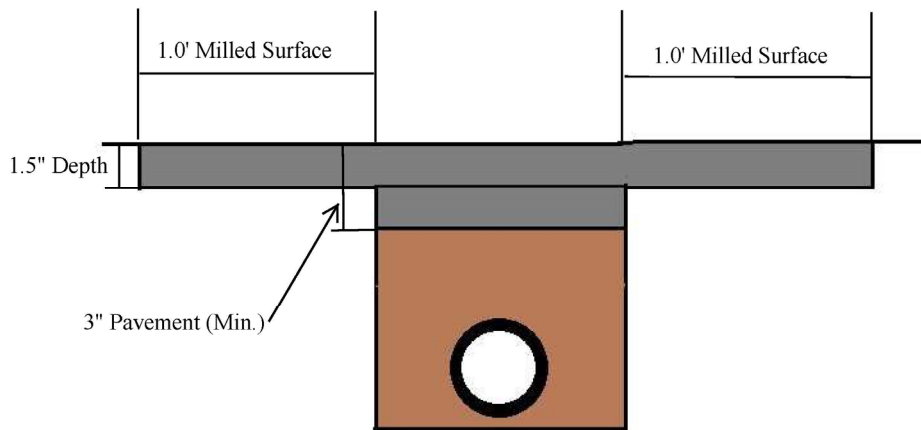

Typical Trench

***All contractors are subject to a 2-year warranty period on trenches within the City's right of way.**

Excavation work must be started no later than 30 days from the date of issuance. After 30 days, this permit will become null and void and shall have to be renewed.

A base fee of \$25 is charged for every permit and street opening charges will be measured and determined after the work is performed based on the Master Fee schedule in the Westbrook Code of Ordinances.

Applicant's Signature _____ Date _____

For Department Use Only

Approved

Disapproved

Public Services Director _____ Date _____

Wastewater Manager _____ Date _____

Note:

- One signature required for approval
- List reasons for rejection on the back of this form